

# A hydraulic analogue study of the Hartmann oscillator phenomenon

By LOUIS SOLOMON†

University of California at Los Angeles, Los Angeles, California

(Received 4 February 1966 and in revised form 19 July 1966)

The Hartmann oscillator problem is studied using the hydraulic analogy between compressible gasdynamics and incompressible flows with a free surface. Extensive photographs, taken of the oscillator in order to visualize the periodic flow, show that qualitative features of the flow agree well with the observations made with a cavity in an air jet.

The construction and operation of the water channel built and used at the University of California at Los Angeles for this study is also described. Continuous ‘shooting’ water flow was found to be analogous to supersonic isentropic gas flow; a static depth of approximately  $\frac{1}{4}$  in. of water appeared to be satisfactory. It seems that the most valuable aspect of the hydraulic analogy is its ability to easily present excellent visualization of flow phenomena, both steady and unsteady.

---

## 1. Introduction

Hartmann (1919) found an oscillating flow occurs when a cavity is aligned axially with a supersonic spatially periodic jet. The rapidity of oscillations makes flow visualization studies by standard techniques, e.g. Schlieren photography, difficult. The hydraulic analogy between supersonic compressible gasdynamics and incompressible flows with a free surface offers a simple means of experimentally studying the qualitative behaviour of the oscillating flow.

§2 deals with previous work on the Hartmann oscillator; a development of the hydraulic analogy is presented in §3. §4 discusses the experimental equipment and procedure used in this investigation, and §5 presents an interpretation of the results. A theory of operation of the Hartmann oscillator is given in §6; in the concluding §7, some limitations on the experimental procedures are discussed.

## 2. Hartmann oscillator

A schematic diagram of the Hartmann oscillator is given in figure 1. It is essentially a Pitot tube and was used by Hartmann (1919) in attempting to determine the stagnation pressure distribution along the axis of a spatially periodic jet (figures 2 and 3). He found that violent acoustic oscillations occur whenever the Pitot tube is located in a region of the jet where the stagnation pressure increases with distance from the nozzle. The wavelength of the oscilla-

† Present address: TRW Systems, One Space Park, Redondo Beach, California.

tion is related to the longitudinal dimension of the rectangular cavity which he substituted for the Pitot tube. These generated frequencies of about 1 kcyc. He also used a large Helmholtz resonator as a cavity, which he called a pulsator; it had a characteristic frequency of a few c/s. For both types of cavities, two major flow conditions were noted: for approximately half the cycle the jet flows into the cavity, with the external detached shock disk situated close to or within the

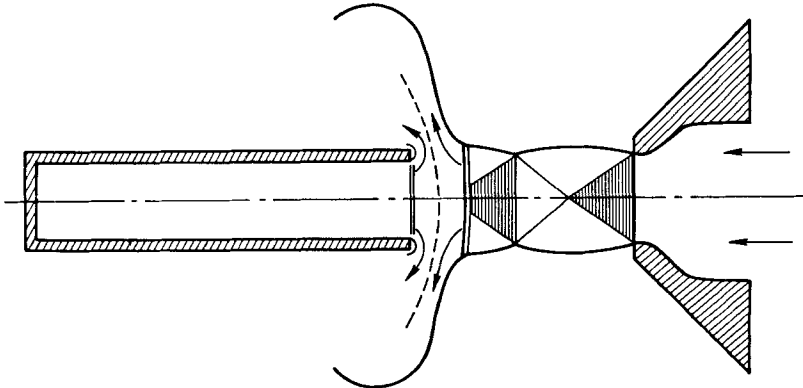

FIGURE 1. Hartmann oscillator.

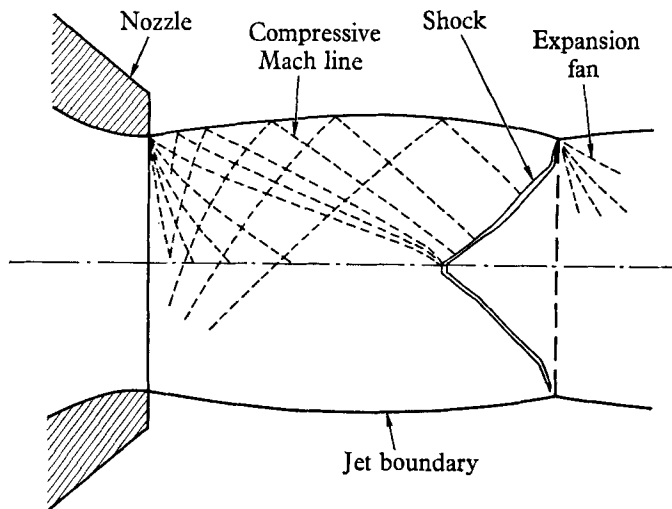

FIGURE 2. Formulation of shock wave in periodic jet efflux.

cavity orifice; then the flow abruptly reverses and there is an impulsive upstream movement of the normal shock with a subsequent discharging of the cavity. As the cavity pressure falls, the shock slowly moves downstream, until it suddenly moves to its original position. Hartmann (1919) made further experiments with very small cylindrical cavities, e.g. length and depth of approximately 0.5 mm. His spark-Schlieren photographs show that external flow variations have the same basic character whether the cylindrical cavities or the pulsator are employed.

Hartmann (1919) proposed a theory of operation for the oscillator. Due to the rapid fluctuations which were about 1 kcyc, however, he did not observe some

features of the flow, internal or external to the cavity. Further studies on the Hartmann oscillator were made by Vrebalovitch (1962), Gravitt (1959), Thompson (1960), Fam (1960), Mørch (1963), Sprenger (1954), Sibulkin & Vrebalovitch (1958), Hall & Berry (1959), Wilson & Ressler (1959), Hartenbaum (1960), Smith & Powell (1964), Solomon (1965*a, b*).

Due to the high frequencies generated by the Hartmann oscillator, standard flow visualization techniques are difficult to use. The hydraulic analogy offers a means of studying unsteady flows. Oscillatory flow in the hydraulic analogy corresponds to oscillatory flow in the gas flow. However, the frequencies in the hydraulic analogy are lower by two to three orders of magnitude than the frequencies encountered in the gas flow. Therefore, by means of the hydraulic analogy high frequency oscillatory flows in gasdynamics may be photographed using conventional equipment.

### 3. Hydraulic analogy

Mach (1887) noted the resemblance between the wave pattern formed by a supersonic projectile and the surface waves produced by a moving ship. The analogy between the steady two-dimensional flow of a gas and the flow of water with a free surface was derived by Jouguet (1920) and Riabouchinsky (1932). The equation describing the two different flows turns out to be identical if the water is replaced by a fictitious 'hydraulic gas' with a ratio of specific heats of 2.0. Preiswerk (1938, 1940) provided an account of the analogy including discontinuities. Ippen, Harleman & Crossley (1950) also discussed the hydraulic analogy. Loh (1960) developed the analogy between one-dimensional unsteady gasdynamics and flows with a free surface.

The National Aeronautics and Space Administration, Langley Field, Virginia, has an operating water tunnel. (The equipment which employs the hydraulic analogy is generally referred to as a water tunnel, or more frequently a water table.) The first use of this NASA facility by Orlin, Lindner & Bitterly (1947) investigates the analogy to subsonic flow about a cylinder. Matthews (1950) discusses the details of design and operation of this water channel. Black & Mediratta (1951) also discuss the construction of a water channel which forms the basis of the design for the UCLA water table.

## 4. Description of the apparatus

### 4.1. *The water channel*

The water channel (figures 4–6) consisted of a horizontal sheet of clear plate glass,  $\frac{3}{4}$  in. thick, with supply tank at one end, and a sump tank at the other. From the sump tank, the water was returned by a small radial pump driven by a 2 h.p. a.c. motor through 4 in. diameter hard rubber pipe. This type of pipe is both lightweight and easily cut; all rubber connections were made with a quick-drying epoxy.

The supply tank was constructed from  $\frac{1}{4}$  in. aluminium sheet welded together. It had external dimensions of 5 ft. by 5 ft. by 2 ft. In order to lessen turbulence and surging, the entrance of the return pipe was shielded with a curved metal

sheet. In addition, five fibreglass screens of no. 18 mesh traversed the tank normal to the flow of water. These hopefully eliminated any large turbulent eddies, or a mean transverse flow within the tank. The water was led up to the glass sheet with a convex dam constructed of stainless steel.

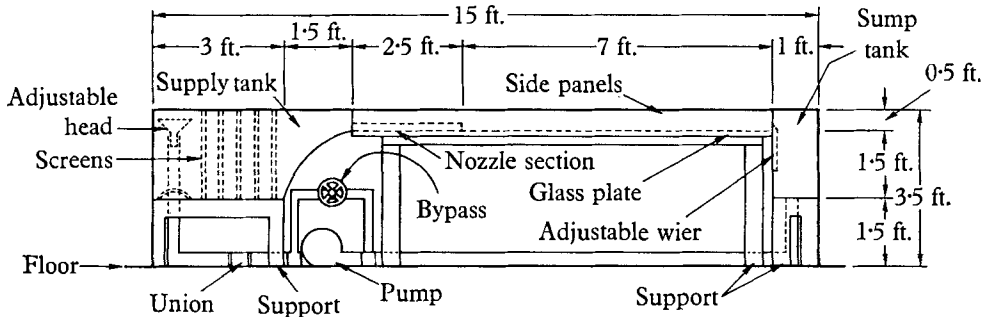

FIGURE 4. Hydraulic analogue, side view.

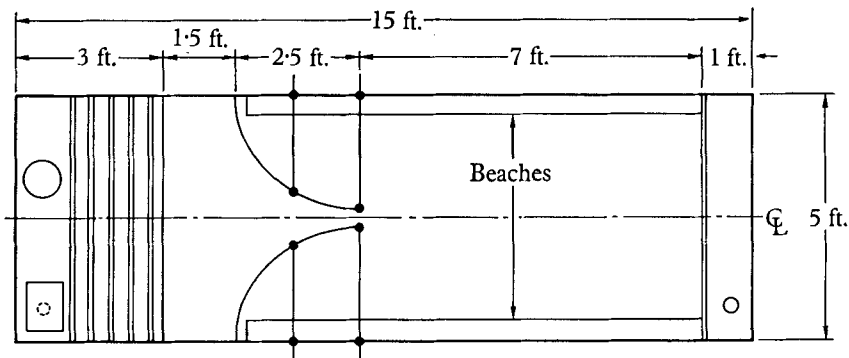

FIGURE 5. Hydraulic analogue, top view.

The glass sheet which served as a channel bottom was 9 ft. by 5 ft. by  $\frac{3}{4}$  in. thick. The sides of the channel were constructed of  $\frac{1}{4}$  in. thick aluminium sheet, 6 in. high, which rested on the edge of the glass, and whose ends were bolted securely to the supply tank and sump tank.

In order to control the height of the water in the glass plate, an adjustable weir running the length of the sump tank was installed. This kept the basic level of the water on the sheet very accurately. Generally, this water depth was about  $\frac{1}{4}$  in. Furthermore, in the supply tank, there was an overflow pipe fitted with a conical section which would be raised or lowered as desired. This kept the head of water in the supply tank at a very steady level regardless of the types of flow taking place in the water channel itself.

The flow entered the water channel through a nozzle (figure 6*a, b*). This nozzle was constructed with two 4 in. high, stainless steel strips. One end of the strip was bolted to a lip of the supply tank at the beginning of the glass sheet. The other end of the strip had a rod pivotally attached about the middle of the strip, in order to be above the water level. There was also one other rod pivotally attached at about the mid-point of the strip. Both rods then ran through two holes placed in the sides of the channel. By using adjustable collars on both sides of the channel

wall, the movement of the rod was completely inhibited. The virtue of this system was that it allowed the strips to be placed in any desired curve by the adjustment of eight collars. The nozzle could then be made to be symmetric, non-symmetric, convergent, convergent-divergent, large (e.g. 1 ft.-wide throat) or small (e.g.  $\frac{1}{4}$  in. throat). This system enabled a rapid simulation of a variety of jet flows exhausting into a lower pressure, which corresponded to the mean water depth in the channel; the mean water depth was set using the weir in the sump tank. Furthermore, if desired, the nozzle strip could be entirely removed and the simulation of an unbounded flow could be easily obtained.

The flow velocity entering the channel was kept constant by using the adjustable overflow pipe. Also, there was a valve in the return line from the sump tank which controlled the flow directly. In addition to the main control valve, a bypass line was installed which could recirculate the water through the pump without entering the supply tank. The overflow pipe returned water to the main pipe upstream of the pump.

Along the sides of the channel, wave absorbers were constructed. These were simply screens rolled into a curve and entering the water at an angle such that it approached the side of the channel at the glass plate. This is a mirror image of a beach. It was found that for entrance angles of about 60 degrees the reflected waves were virtually dissipated in one or two wavelengths.

#### 4.2. *Measuring apparatus*

There are two types of measurements which can easily be made using the hydraulic analogy: (1) direct measurement of the water depth, and (2) direct pressure measurements.

Depth measurement of the fluid could be made at any point in the flow with an accuracy of  $\pm 0.001$  in. using a micrometer depth gauge carrying a probe. The probe was simply a fine needle. The needle was allowed to be moved vertically by means of a micrometer with a range of  $\frac{1}{2}$  in. For distances over  $\frac{1}{2}$  in. the needle assembly was able to be moved in  $\frac{1}{2}$  in. steps. Vertical alignment was possible with three levelling screws and a bubble. It was found that the action of the needle striking the water could be easily observed and no electrostatic probe was required. The probe was placed on a movable trolley which extended across the channel; it had bracing so that its deflexion in the centre was negligible. The trolley could move the entire length of the channel along guide rails erected on the side of the tank. One rail was horizontal; the other was inclined to the first at 45 degrees. A single point of contact on one side of the trolley was provided by a small roller bearing attached vertically to the trolley and running along the horizontal guide rail. The other two points of support on the opposite side also provided lateral restraint; they each consisted of a pair of small ball bearing wheels mounted so that a V was formed in order to securely make contact with the rail. These were spaced 16 in. apart. The rails were made horizontal by employing an engineer's level.

In order for the hydraulic analogy to operate accurately, it is necessary to have the glass sheet horizontal. The wooden structure on which the glass was placed had eight legs, each of which had an adjusting screw in its foot which enabled the

structure to be raised or lowered at that point. When the glass was in place, it was thoroughly cleaned. Then water was placed on the upper surface in little pools. The legs were then adjusted until the water remained in a steady position. Later the level of the sheet was checked with the engineer's level.

#### 4.3. *Photographic technique*

Various types of lighting systems were used, depending upon the types of pictures desired. Basically pictures were taken directly of the water surface.

A shadowgraph-Schlieren-type system was employed for the hydraulic analogue. A beam of nearly parallel light rays was formed by using a length of stovepipe, and then reflected by a plain mirror. It then passed through a frosted glass sheet, and fell upon the curved water surface where it was refracted. The refracted beam was reflected by another plain mirror into the camera lens which was focused upon the frosted glass sheet. This is basically a shadowgraph system, but the gradient of height is seen, not the height itself. Therefore, the system has qualities of both Schlieren and shadowgraph systems.

The time-dependent phenomena were photographed using a Bolex 16 mm movie camera, with TRI-X and Plus X negative movie film, operating at a speed of 32 frames/sec and  $f/3.5$  aperture. From the motion pictures, wave velocity could be obtained, as well as the period of the cycle.

#### 4.4. *Models*

For the photographic investigation of the Hartmann oscillator phenomenon, several different cavities were used (figure 6*k, l*). They were constructed of lucite. The rectangular cavities were 2 in. wide, and ran from 2 to 18 in. in length. There were also two models built of the pulsator, one having an inlet length of 3 in. with a cavity diameter of 5 in. and the other having an inlet length of 12 in. with a cavity diameter of 12 in.

### 5. Interpretation of the photographic studies

There were six photographic records made of the three different models used in the Hartmann oscillator studies. One set of photographs was made such that the flow was seen from directly above the model, as in a plane view, while the other set of photographs taken of the same model was taken at an oblique angle in order to obtain some perspective.

The set of photographs were obtained in the following manner: a 16 mm Bolex motion picture camera was used to take motion pictures of the flow using negative film. From the negative film a positive 16 mm print was made; also,  $4 \times 5$  in. still photographs were made from sequentially selected negatives at different points in the periodic cycle. This procedure provided not only still photographs of the flow which were of great help in studying particular points, but also allowed the study of the entire periodic flow as well as an estimation of how much of the period was allotted to each phase of the cyclic flow.

The primary feature of the flow which is easily recognizable is the hydraulic jump, which corresponds to a shock wave in the analogy. The formation of vortices can be seen as well.

### 5.1. *The rectangular cavities*

The remarks concerning the rectangular cavities are applicable to all the rectangular cavities, irrespective of their length. The only difference between the models was one of length; the only discernible differences in their flows were the period of oscillation, which is definitely related to the length of the cavity, and the intensity of the hydraulic jumps. In substance, however, the flows were similar, i.e. identical except for a change of scale (figures 7, 8).

The first picture of the cycle starts with the periodic jet being terminated by a stationary hydraulic jump attached to the lip of the cavity and normal to the flow. This is referred to, in the gas dynamic case, as the Riemann shock. Within the cavity, a second hydraulic jump (which is moving) is seen to be almost at the end of the cavity. There are also two hydraulic jumps outside the cavity which are approximately one cavity diameter downstream from the cavity mouth. In the gasdynamic case, this hydraulic jump would correspond to an axisymmetric shock wave. The rest of the external flow is seen to be essentially tranquil, as is the internal flow within the cavity. (The bar normal to the flow near the mouth of the cavity is merely there for structural purposes, and is located well above the water, so it does not interfere with the flow in any way.) Due to the normal hydraulic jump located at the mouth of the cavity, the great portion of fluid in the jet entering from the top of the picture is diverted around the cavity.

In the following photographs, the external hydraulic jumps remain virtually at rest; the pictures, in fact, are almost identical to the first, except for the readily apparent movement of the hydraulic jump inside the cavity. When this hydraulic jump collides with the normal hydraulic jump attached to the mouth of the cavity, both merge into one hydraulic jump, and a cylindrical wave is formed, moving upstream into the jet efflux, as well as into the quiescent fluid.

The next photographs clearly show the outward movement of a hydraulic jump which would correspond to a radiated sound wave. That portion of the hydraulic jump remaining in the jet moves upstream and remains in a fairly stationary position. The fluid within the cavity discharges with the subsequent formation of two large eddies which in the gas case would correspond to an intense ring vortex. Furthermore, the rapid discharge of the fluid from the cavity into the ambient field causes the formation of two strong hydraulic jumps which are curved in roughly a parabolic shape, concave upstream. These appear to be directly influenced by the formation of the vortices cast off from the lip of the cavity. There also appears briefly in the flow a second normal shock outside the cavity. That is, due to the efflux of fluid from the cavity directly into the jet, a stagnation point develops which lies along the axis of the jet, approximately one cavity diameter upstream of the mouth of the cavity. A fluid particle leaving the cavity in an upstream direction, or entering the field in the jet, is in 'shooting' flow, i.e. the Froude number is greater than one. This corresponds in gasdynamics to supersonic flow. In order to come to rest at a stagnation point, it must go through a hydraulic jump in the water case, or a shock wave in the gas dynamic case. This explains the double shock system seen in figures 7*j* and 8*o*. Furthermore, the region between these two normal hydraulic jumps is separated by an

interface which is a stream line, also normal to the jet flow, and on which the stagnation point lies. This interface is characterized by the fact that on it, all normal components of velocity are zero. The two parabolic external hydraulic jumps subsequently separate from the cavity and establish themselves parallel to the jet flow direction, but downstream of the interface line. These hydraulic jumps are formed by the fluid discharging from the cavity, which is turned by the interface boundary condition and the vortices which are now detached from the lip of the cavity and are 'free' in the flow field.

As the cavity is of only finite dimensions, the condition for the interface to remain at rest, namely, equal stagnation pressure from both the jet flow and the fluid discharge from the cavity *after* passing through their respective normal hydraulic jumps cannot be met indefinitely. When this occurs, the hydraulic jump formed by fluid from the jet, which is upstream of the interface, moves rapidly downstream toward the cavity mouth. The hydraulic jump formed by fluid discharging from the cavity, which is downstream of the interface, as well as the interface, disappears, and fluid begins to enter into the cavity. In general, the conditions downstream of the normal hydraulic jump external to the cavity do not correspond to the conditions within the cavity. This causes a second hydraulic jump to form within the cavity, and to move downstream toward the end of the cavity with a velocity dictated by its strength. The external hydraulic jumps diminish in intensity and return to their basic attached position approximately one cavity diameter downstream of the cavity mouth. The external normal hydraulic jump re-establishes itself at the mouth of the cavity.

### 5.2. *The cylindrical cavity*

The flow phenomena caused by the cylindrical cavity (figure 9) are basically the same as those of the rectangular cavities, which were described at some length above. The external hydraulic jump structure is the same, as well as the normal hydraulic jump pattern within the jet; vortex formation is also identical. The free movement of the vortices, however, is different due to the different boundary conditions caused by a different body shape. However, to all intents and purposes the essential features of the external flow are unchanged. Internally there are differences in the flow.

It will be recalled that upon reattachment of the external normal hydraulic jump to the cavity mouth and due to the mismatch between the conditions downstream of the hydraulic jump and the conditions within the cavity, a second normal hydraulic jump was formed and moved in a downstream direction within the cavity. When this hydraulic jump encounters the abrupt change of diameter from the neck of the cavity to the cavity chamber, it begins to form a spherical wave-front. However, the boundary conditions needed to maintain such a wave-form cannot be met in the vicinity of the walls of the cavity. In sum, therefore, it is easily seen that waves are being continuously formed within the cavity, and interacting with one another. The net result is an increase in pressure, which corresponds to an increase in height of the water. This pressure eventually reaches the stagnation pressure corresponding to that of the normal hydraulic jump at the mouth of the cavity.



Due to the fact that this flow within the cavity is characterized by time-dependent travelling waves, it can be recognized that some waves will be able to travel upstream toward the hydraulic jump at the mouth. Those which are expansive in nature tend to cause the hydraulic jump to move into the cavity. But those which are compressive in nature cause the hydraulic jump to move upstream. The hypothesis of normal hydraulic jump instability was advanced due to the fact that even when perturbed by small compression hydraulic jumps, the strong normal hydraulic jump moved rapidly upstream to a position approximately one cavity neck diameter upstream of the cavity mouth. That is, a shock wave or hydraulic jump within the cavity is *not* required to cause the cycle to commence and be maintained, but rather, a necessary condition for the occurrence of the Hartmann resonance phenomenon is that the cavity is placed in a portion of the periodic jet cell where the normal hydraulic jump is unstable. The unstable portions of the jet cell were found to be the compression regions; the stable portions were found to be the expansion regions.

All the gasdynamic cases investigated by Hartmann (1919) were characterized by axisymmetric jets. When Smith & Powell (1964) investigated the possibility of a two-dimensional jet impinging upon a two-dimensional cavity, it was found that under no conditions were oscillation of the Hartmann type found to occur for any position of the cavity along the jet axis. This was attributed to the fact that for the same pressure ratio of exit nozzle pressure to ambient pressure, the variations in Mach number along the axis are far greater in the axisymmetric case than in the two-dimensional case. The reason why the hydraulic analogy of the Hartmann oscillator works seems to be related to the value of  $\gamma = 2.0$ . This gives axial variations of Mach number for the two-dimensional case of the same order as Mach number variation in the axisymmetric case when  $\gamma = 1.4$ . Furthermore, the boundary-layer build-up on the glass sheet between the nozzle exit and the cavity mouth contributes an effect which does not exist in the two-dimensional gasdynamics case.

## 6. Theory of operation of the Hartmann oscillator

(1) Consider the cavity mouth to be located in the jet at some point so that the associated normal shock lies within the compression region of the cell which is known as an unstable zone.

(2) Initially the jet flows into the cavity with the detached shock located very close to the orifice of the cavity. This position is known as the quasi-stable downstream location of the shock.

(3) As the cavity fills, the pressure within it will increase, and there will be a distinctive internal flow taking place within the cavity. In the case of a cylindrical tube, this flow will be characterized by a shock moving into the tube, reflecting from the end, and returning to the orifice; in the case of a Helmholtz resonator, this flow will be characterized by a shock moving into the neck of the cavity but reflected at the cavity entrance as an expansion fan. However, due to the finite volume of the cavity, the continuing influx of fluid from the jet will cause the cavity to continue to increase its pressure and eventually a compression wave

will be generated from the cavity which will move upstream toward the cavity orifice.

Thus in either the case of the cylindrical resonance tube or in the case of the Helmholtz cavity a compression wave will be emitted by the cavity to interact with the detached shock referred to in (2).

(4) It appears that due to the steadily increasing Mach number with axial movement upstream, the perturbed detached shock will move rapidly upstream. This initiates a radiated pressure wave as the cavity proceeds to discharge in the form of a second spatially periodic jet. As the shock moves upstream its velocity is rapidly attenuated by a series of expansion waves and will further be slowed by encountering a region of decreasing Mach number in the upstream direction. This region of the jet, known as the stable zone, is a region of expansion. The shock stops at a position in the stable zone which is the quasi-stable upstream location of the shock.

(5) Due to the efflux of fluid from the cavity, the pressure within it drops, and the normal shock gradually moves back downstream until it reaches the limit of the quasi-stable upstream position of the shock. It then moves impulsively back to the cavity mouth. The cavity, of course, then begins to fill and the cycle is begun again.

(6) If the cavity mouth is located at some point so that the associated normal shock lies within the expansion region of the cell, which is known as the stable zone, then the perturbed shock will not move rapidly upstream; this appears to be due to the steadily decreasing Mach number with axial distance upstream. With the normal shock in a stable zone of a jet cell, therefore, steady-state oscillations will not occur.

## 7. Conclusions

The Hartmann oscillator phenomenon has been extensively studied, and various modes of operation have been suggested. Based upon the studies made using the hydraulic analogy, it appears that the basic problem to be investigated is that of shock stability in a flow where the upstream Mach number varies with axial distance. The solution of such a problem would also aid in understanding the supersonic 'buzz' problem encountered near the entrance of supersonic inlets.

The water channel provides a convenient analogous flow to the flow of a gas. When the general gas flow is well understood, this inexact analogy offers little knowledge. However, in gas flows which are not well understood, the qualitative knowledge about their behaviour which can be easily obtained through this analogy may be valuable.

The help of Professor Nicholas Rott in postulating a theory of operation is gratefully acknowledged. His constant encouragement and clear insight into the problem were a tremendous source of comfort and assistance. Also I would like to thank Alan Powell for introducing me to the problem and for many helpful discussions in its initial stages. The financial support by the office of Naval Research of the work done under the Fluid Motion and Sound Contract Nonr 233(62) is also gratefully acknowledged.

## REFERENCES

- BLACK, J. & MEDIRATTA, O. P. 1951 Supersonic flow investigations with 'hydraulic analogy' water channel. *Aero. Quart.* **2** (4), 227-53.
- FAM, S. 1960 A photographic study of resonance tubes. M.S. Thesis, Mass. Inst. of Technology, Cambridge, Mass.
- GRAVITT, J. C. 1959 Frequency response of an acoustic air-jet generator. *J. Acoust. Soc. Am.* **31**, 1516-18.
- HALL, I. M. & BERRY, C. J. 1959 On the heating effect in a resonance tube. *J. Aero/Space Sci.* **26**, 253.
- HARTENBAUM, B. 1960 Hydraulic analog investigation of the resonance tube. M.S. Thesis, Mass. Inst. of Technology, Cambridge, Mass.
- HARTMANN, J. 1919 Om en ny Metode til Frembringelse af Lydsvinginger. *Dan. Mat. Fys. Medd.* **1**.
- IPPEN, A. T., HARLEMAN, D. R. F. & CROSSLEY, H. E. 1950 Studies on the validity of the hydraulic analogy to supersonic flow. Mass. Inst. of Technology Hydrodynamics Laboratory, U.S. Air Force TR 5985.
- JOUGUET, E. 1920 Some problems in general hydrodynamics. *J. Math. pures appl.* Series 8, **3**, (1).
- LOH, W. H. T. 1960 Hydraulic analogue for one-dimensional unsteady gas dynamics. *J. Franklin Inst.* **269**, (1), 43-55.
- MACH, E. 1887 Photography of projectile phenomena in air. *Sber. wien. Akad.* **95**, 164.
- MATTHEWS, C. W. 1950 The design, operation, and uses of the water channel as an instrument for the investigation of compressible flow phenomena. *NACA TN* 2008.
- MØRCH, K. A. 1963 Shock instability in the Hartmann air jet generator. Tech. University of Denmark, Fluid Mechanics Lab. *Rept. LFM R* 63-2.
- ORLIN, W. J., LINDNER, N. J. & BITTERLY, J. G. 1947 Application of the analogy between water flow with a free surface and two-dimensional compressible gas flow. *NACA TN* 1185.
- PREISWERK, E. 1938 Applications of the methods of gas dynamics to water flows with free surfaces: Part I. *NACA TM* 934.
- PREISWERK, E. 1940 Applications of the methods of gas dynamics to water flows with free surfaces: Part II. *NACA TM* 935.
- RIABOUCHINSKY, D. 1932 Sur l'analogie Hydraulic des Movements d'un Fluid Compressible. *C. r. Acad. Sci.* **195** (22), 998-9.
- SIBULKIN, M. & VREBALOVICH, T. 1958 Some experiments with a resonance tube in a supersonic wind tunnel. *J. Aero/Space Sci.* **25**, 465-6.
- SMITH, T. & POWELL, A. 1964 Experiments concerning the Hartmann whistle. University of California, Los Angeles, Department of Engineering *Rept. no.* 64-42.
- SOLOMON, L. 1965*a* Interaction of supersonic jets with cavities. Ph.D. Dissertation, University of California, Los Angeles, California.
- SOLOMON, L. 1965*b* A hydraulic analog study of the Hartmann oscillator phenomenon. University of California at Los Angeles, Department of Engineering *Rept. no.* 65-46.
- SPRENGER, H. 1954 Thermal effects in resonance tubes. *Mitt. Inst. Aerodyn. E.T.H.* **21**, 18-24. Zürich.
- THOMPSON, P. A. 1960 Resonance tubes. Ph.D. Dissertation, Mass. Inst. of Technology, Cambridge, Mass.
- VREBALOVICH, T. 1962 Resonance tubes in a supersonic flow field. Jet Propulsion Lab., California Institute of Technology, *Tech. Rept.* **32**, 378.
- WILSON, J. & RESSLER, E. L. 1959 A mechanism of resonance tubes. *J. Aero/Space Sci.* **26**, 461-2.



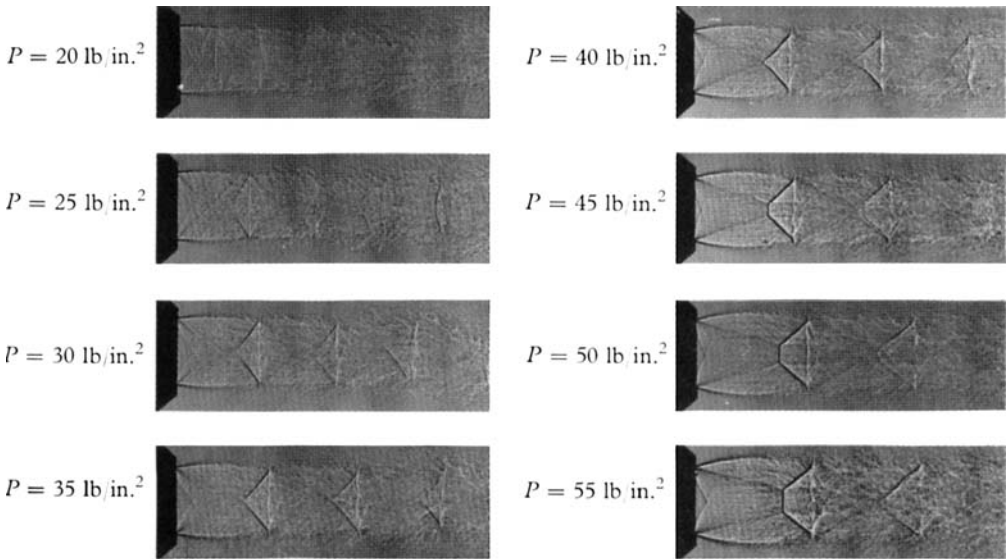

(a)

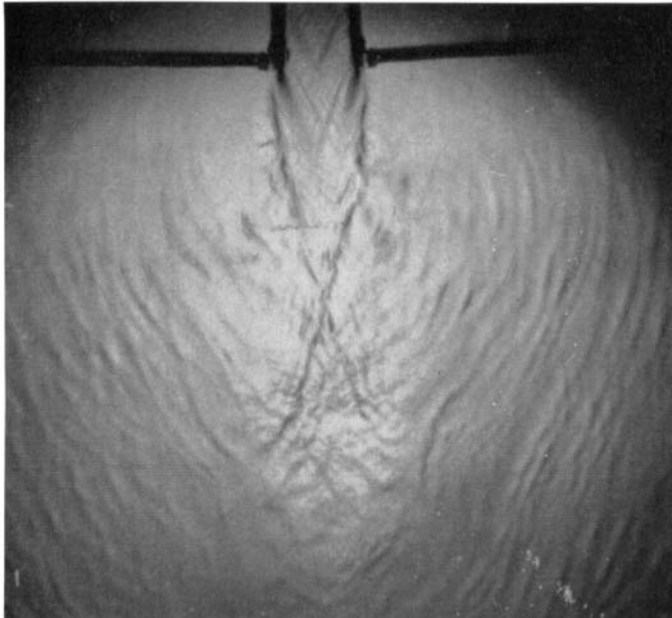

(b)

FIGURE 3. Spark-shadowgraphs of periodic jet effluxes and a hydraulic analogue of a periodic jet.

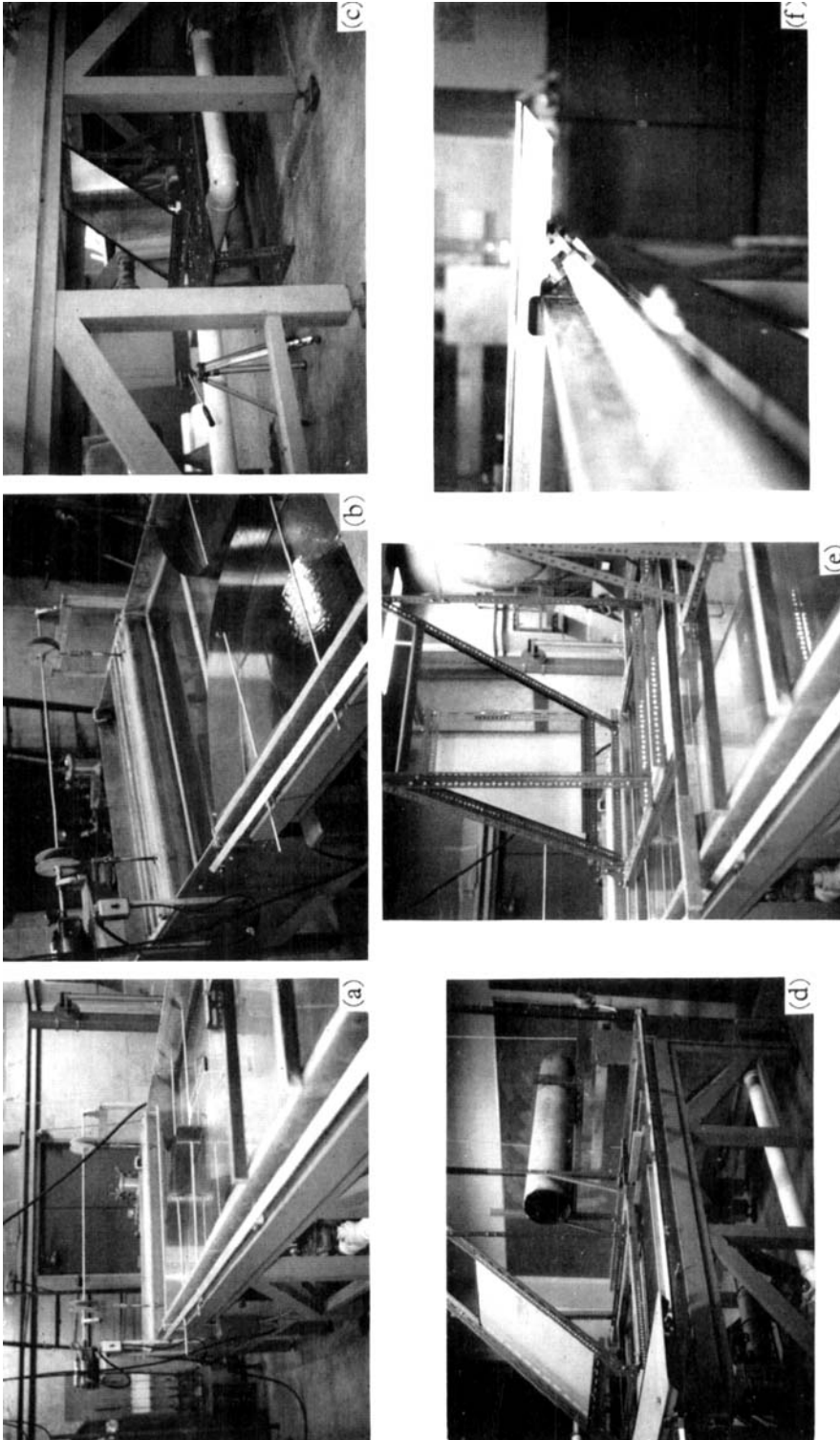

FIGURE 6 *a-f*. For legend see facing page.

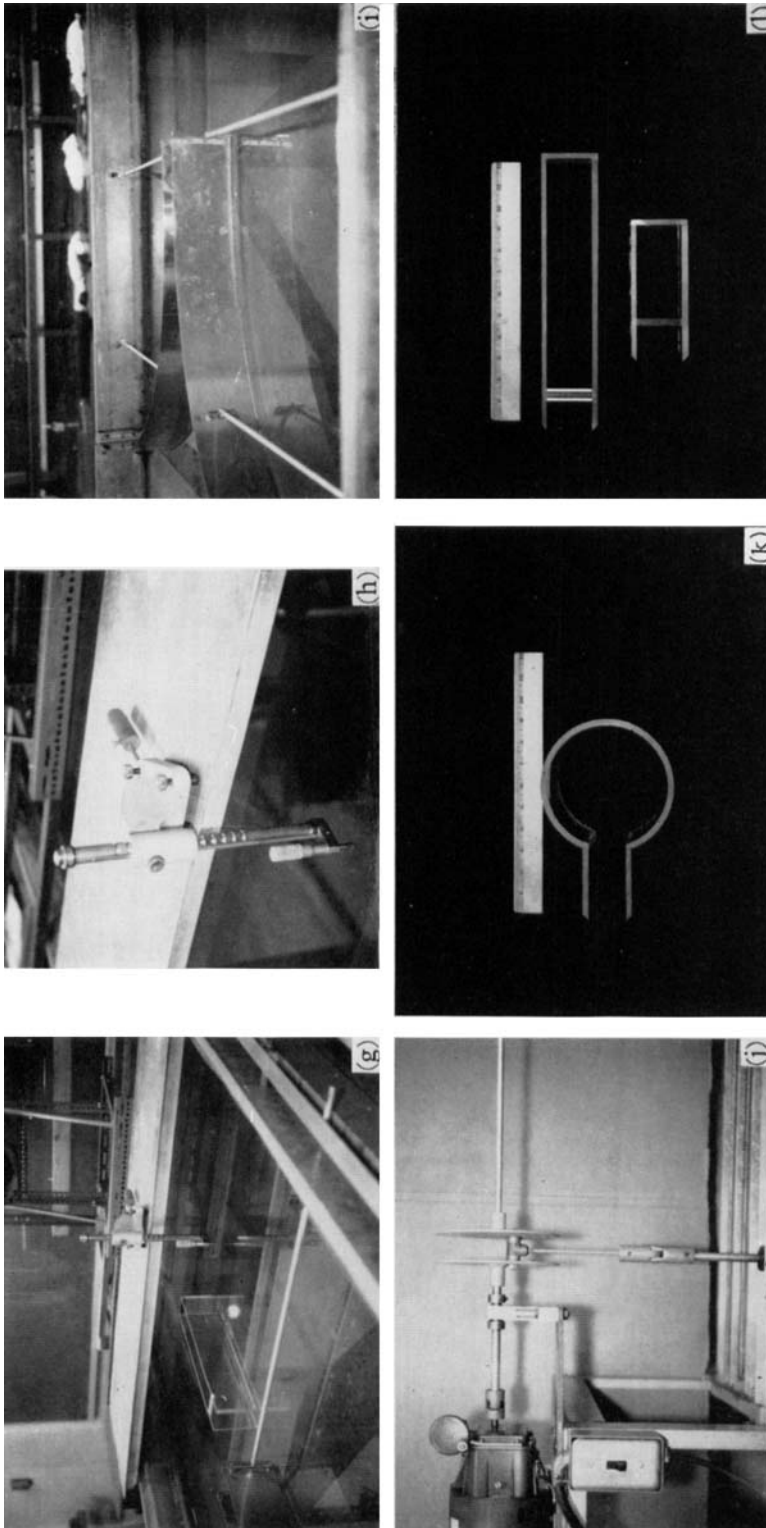

FIGURE 6. Views of hydraulic analogue and ancillary equipment. (a) Glass plate and nozzle. (b) Supply tank and nozzle. (c) Bottom reflecting mirror and support structure. (d) Top reflecting mirror and parallel ray light source. (e) Top reflecting mirror and frosted lucite. (f) Detail of rail and trolley mounting. (g) Trolley, model, and height gauge. (h) Detail of height gauge. (i) Rectangular construction. (j) Detail of periodic wave generating mechanism. (k) Helmholtz cavity. (l) Rectangular cavity.

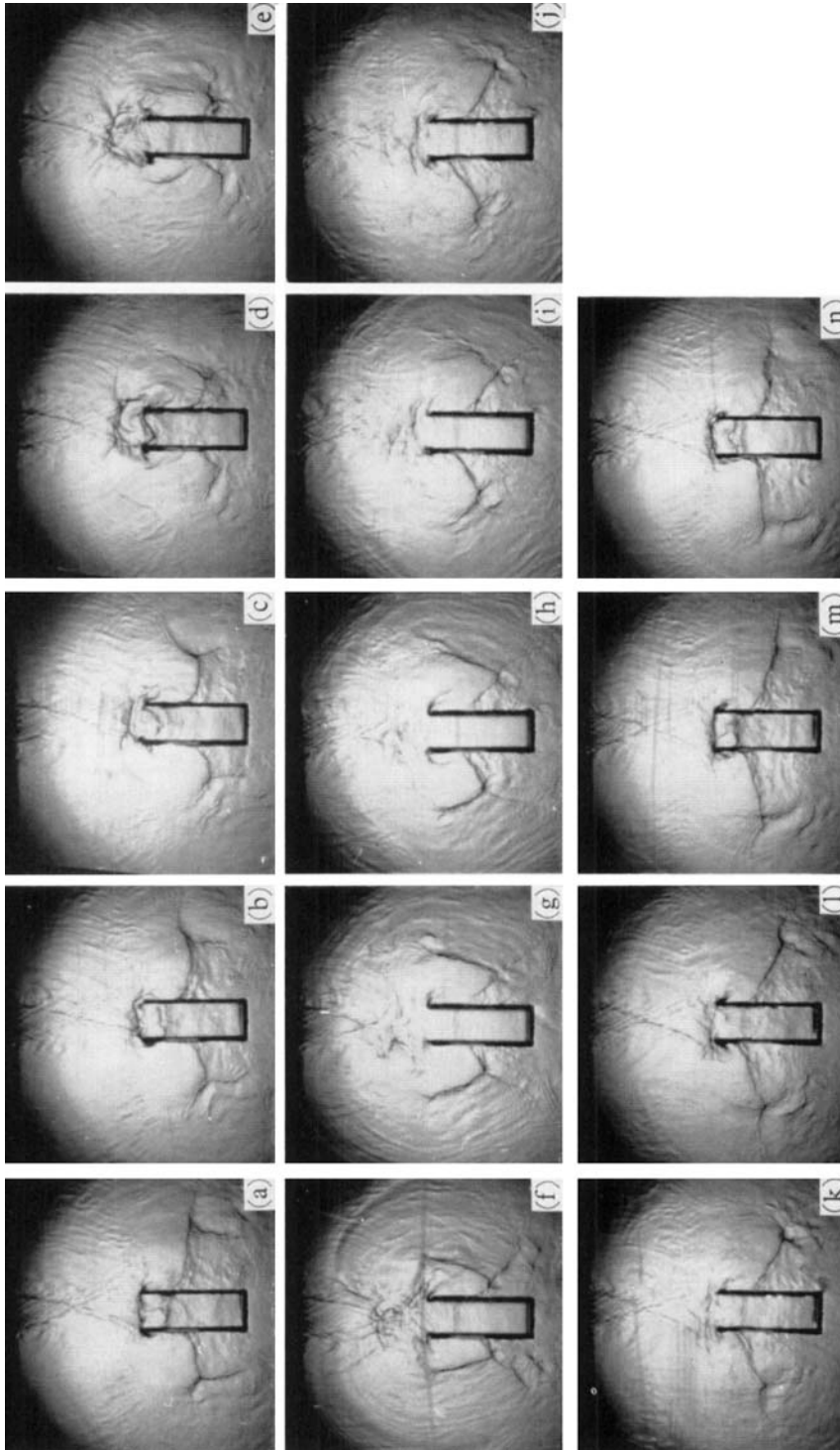

FIGURE 7. The hydraulic analogue of one cycle of a Hartmann oscillator (short rectangular cavity).



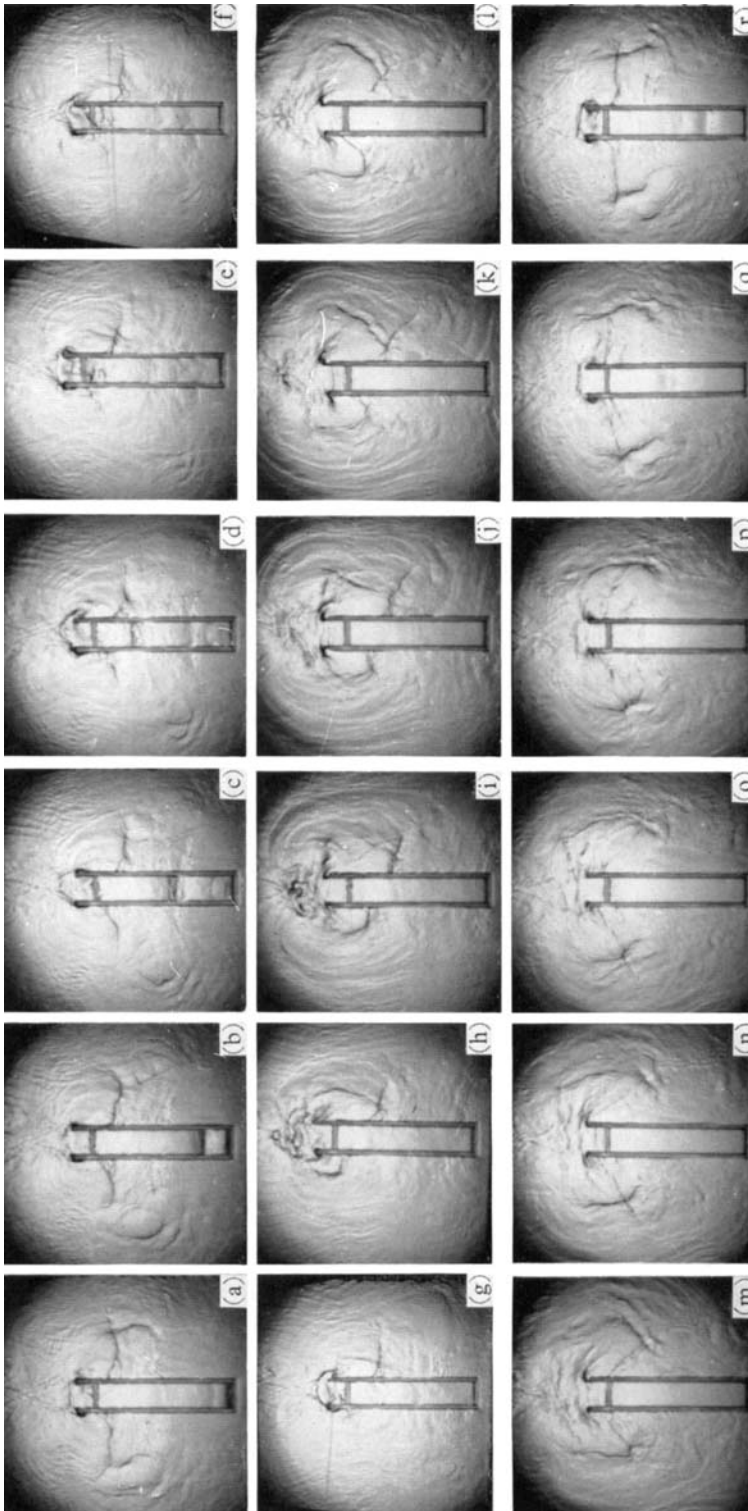

FIGURE 8. The hydraulic analogue of one cycle of a Hartmann oscillator (long rectangular cavity).

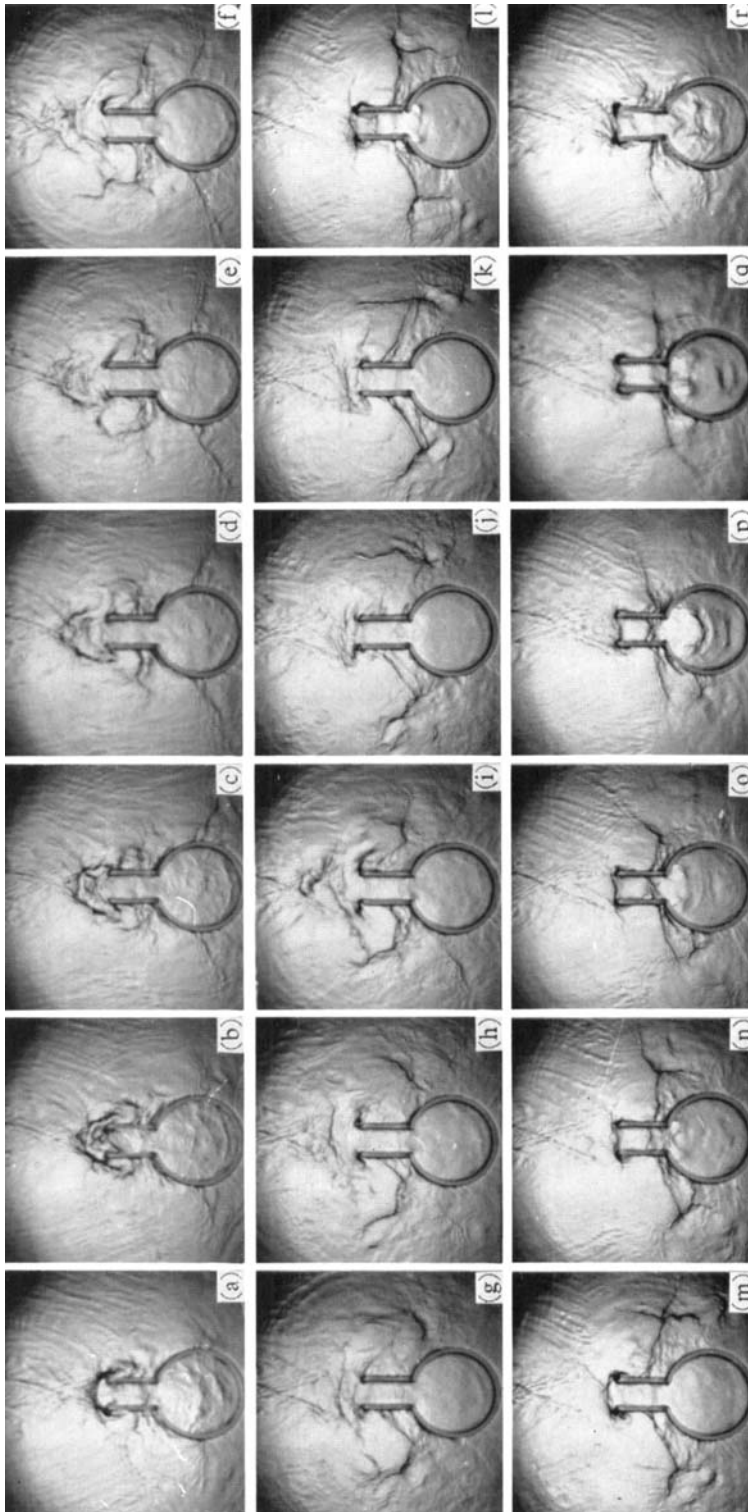

FIGURE 9. The hydraulic analogue of one cycle of a Hartmann oscillator (Helmholtz cavity).